

A 1:4

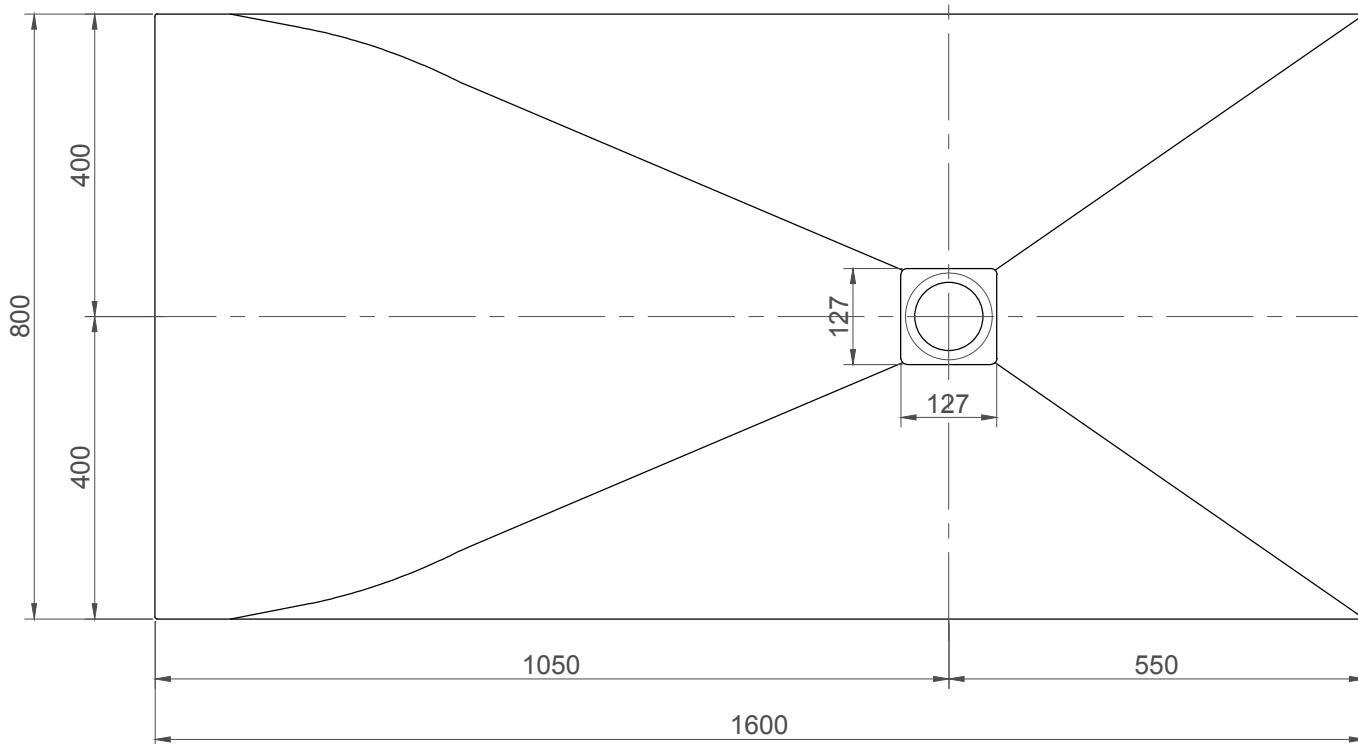
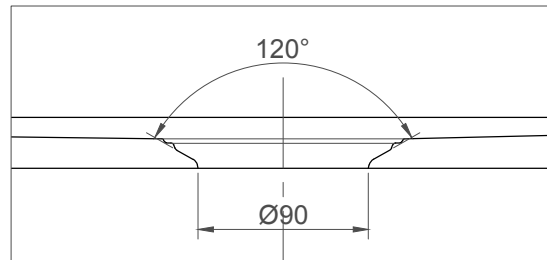

All drawing units are expressed in mm

Rev.	DESCRIPTION	DATE	DESIGNED	APPROVED	SURFACE STATE			
01					GENERAL			
02						Surface for hydraulic seal		
03						Surface subject to surface finish		
CODE	SCALE			DESIGNED	APPROVED	WEIGHT (kg)	Unlisted tolerance:	
S16080	1:10			DATE 02/05/24	03/05/24	62	Unlisted rays R:	
				SURNAME SG	LB		Unlisted chamfers:	
						SCOPE		
						Production		
						Data sheet		
						Price list		
						Tech. equipment		
						Technical specific.	X	